

Overview of FLUSH-MOUNTED fans **ECO**

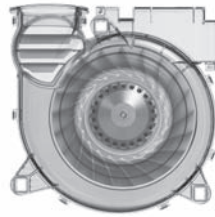

SILENT **ECO** 

	SILENT ECO U 60	SILENT ECO U 100	SILENT ECO U 60 F90	SILENT ECO U 100 F90
STANDARD designs				
Silenced facing in a high-gloss look with filter, white, ~RAL 9016, extraction through lateral shadow gaps	●	●	●	●
Fan unit with maintenance-free, energy-saving external rotor motor with constant volume flow characteristic	●	●	●	●
Plastic casing with cold smoke damper, installation depth 98 mm	●	●		
Fire resistant casing with cold smoke damper and FLI 90 fire damper, installation depth 140 mm			●	●
Exhaust air vent NW 75/80 top	●	●	●	●
ACCESSORIES and special designs (to be ordered separately, subject to additional charge)				
Pluggable delayed shut-off relay, delayed switch-on/switch-off, fixed time settings, type NRS Additional name: ... NRS ...	●	●	●	●
Pluggable delayed shut-off relay, switch-on delay and lag time adjustable, type NRS/E Additional name: ... NRS/E ...	●	●	●	●
Pluggable lag time interval controller, switch-off delay and interval period adjustable, type INS/ECO Additional name: ... INS/ECO ...	●	●	●	●
Two-speed design Additional name: ...GL...	●	●	●	●
Hygrostat, built into the facing Additional name: ...HGEECO...	●	●	●	●
Exhaust air vent NW 75/80 rear Additional name: ... Ø 75/80 rear	●	●	●	●
Intake manifold for adjoining room extraction NW 75/80 (state left, right or bottom when ordering)	●	●	●	●
Intake manifold for WC bowl extraction NW 40/50 (state left, right or bottom when placing order)	●	●		
Installation bracket, plastic, type MBK	●	●		
Installation bracket, metal, type MBM	●	●	●	●

Function description of the automatic hygrostat for Silent ECO fans with a built-in hygrostat HGEECO:

Cutaway facing



built-in hygrostat

The HGEECO hygrostat built in to the facing automatically switches the fan on when the set humidity level is reached (e.g. when showering) and off again after drying. For meteorological reasons it may not always be possible to set the relative humidity level lower than 70% during summer. The user can adjust the setpoint to adapt the humidity sensor to these conditions. Recommended setpoint adjustment by the user: summer: 75 – 80% rh., winter: 65% rh. The summer setpoint is set when the fan starts to run permanently and no longer switches off automatically.

The following control options are available:

One-speed design: high level operation via HGEECO and/or (light) switch.



One-speed design with factory-fitted delayed shut-off relay: high level operation via HGE ECO and/or delayed shut-off relay.

Base load design (2-speed): HGEECO activates low level, (light) switch or delayed shut-off relay activates high level or:

Base load design (2-speed): fan runs permanently on low level, switch, HGEECO and/or delayed shut-off relay activates high level.

For technical details [see page 3.13](#)

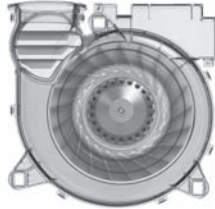
Overview of SURFACE-MOUNTED fans **ECO**

  		SILENT ECO A 60	SILENT ECO A 100	SILENT ECO A 60 F90	SILENT ECO A 100 F90
		STANDARD designs	Surface-mounted casing with silenced facing in a high-gloss look with filter, cold smoke damper, white, ~RAL 9016, extraction through lateral shadow gaps	●	●
	Fan unit with maintenance-free, energy-saving external rotor motor with constant volume flow characteristic	●	●	●	●
	FLI 90 - fire damper			●	●
	Exhaust air vent NW 75/80 rear	●	●	●	●
ACCESSORIES and special designs (to be ordered separately, subject to additional charge)	Pluggable delayed shut-off relay, delayed switch-on/switch-off, fixed time settings, Type NRS Additional name: ... NRS ...	●	●	●	●
	Pluggable delayed shut-off relay, switch-on delay and lag time adjustable, type NRS/E Additional name: ... NRS/E ...	●	●	●	●
	Pluggable lag time interval controller, switch-off delay and interval period adjustable, type INS/ECO Additional name: ... INS/ECO ...	●	●	●	●
	Two-speed design Additional name: ...GL...	●	●	●	●
	Hygrostat, built into the facing Additional name: ...HGEECO...	●	●	●	●
	Exhaust air vent NW 75/80 top Additional name: ... Ø 75/80 top	●	●		

Function description of the automatic hygrostat for Silent ECO fans with a built-in hygrostat HGEECO:

Cutaway facing



built-in hygrostat

The HGEECO hygrostat built in to the facing automatically switches the fan on when the set humidity level is reached (e.g. when showering) and off again after drying. For meteorological reasons it may not always be possible to set the relative humidity level lower than 70% during summer. The user can adjust the setpoint to adapt the humidity sensor to these conditions. Recommended setpoint adjustment by the user: summer: 75 – 80% rh., winter: 65% rh. The summer setpoint is set when the fan starts to run permanently and no longer switches off automatically.

The following control options are available:

One-speed design: high level operation via HGEECO and/or (light) switch.

One-speed design with factory-fitted delayed shut-off relay: high level operation via HGEECO and/or delayed shut-off relay.

Base load design (2-speed): HGEECO activates low level, (light) switch or delayed shut-off relay activates high level or:

Base load design (2-speed): fan runs permanently on low level, switch, HGEECO and/or delayed shut-off relay activates high level.

For technical details [see page 3.13](#)

FLUSH-MOUNTED FanECO – Energy-Saving Motor – SILENT ECO U ... series

Flush-mounted fan for venting bathrooms, WCs, non-commercial kitchens (exhaust air of the room), storage rooms, ... suitable for connecting to a shared rising mains (single pipe system), for wall and ceiling installation.



TECHNICAL DESCRIPTION

- pressure volume flow characteristic curve certified pursuant to Austrian Standard ÖNORM H 6036, air backflow flap designed as a cold smoke damper, temperature resistant up to 200°C, air leak rate <0.01 m³/h, certified by accredited inspecting authority TÜV SÜD Munich
- -certified, hose-proof IPX5, suitable for installation in the safe areas of showers and baths
- protection class II, no grounding conductor required

- easy to exchange air backflow flap
- silenced designer facing and filter bracket in high-gloss look, white, ~RAL 9016
- easy to exchange large-surface filter
- device pivots by 10° for perpendicular equalisation plaster equalisation up to -30 mm
- fan unit with Quick Snap technology for screwless quick fitting with a vibration-absorbing bracket for insulation against structure-borne noise
- easy to install silenced facing through the use of self-tapping screws
- trouble-free electrical connection through pre-wired pluggable motor including control electronics and connection for a pluggable delayed shut-off relay type NRS or NRS/E or an interval delayed shut-off device type INS/ECO
- max. permissible exhaust air temperature 40°C

MOTOR

maintenance-free, energy-saving external rotor motor with constant volume flow characteristic with a direct-mounted, low noise / low energy high-performance impeller and built-in thermal contact, pre-wired and pluggable, 2-speed GL design

FAN UNIT

volute casing and base plate made of tough polycarbonate, temperature resistant up to 150°C

CASING

98 mm installation depth, made of ABS, with integrated cold smoke damper, three pre-punched slots for WC bowl or adjoining room extraction
 Ø 40/50 or Ø 75/80 (surcharge applies for the respective connecting piece), exhaust air vent to the top (or to the rear), conical for pipes with an inner diameter of 75 – 80 mm

Casings are also available with a fire-resistant coating and maintenance-free fire damper against fire transmission as fire-prevention measures - see technical documentation for SILENT ECO U ... F90.

DIMENSIONS

Standard: fan with exhaust air vent Ø 75/80 top.
 The fan is also available with a rear exhaust air vent
 Ø 75/80, type designation:
 SILENT ECO U ... Ø 80 rear

INSTALLATION VARIANTS

Exhaust air vent top

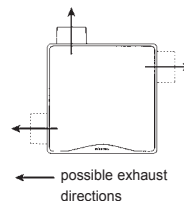

INSTALLATION VARIANTS

Exhaust air vent rear

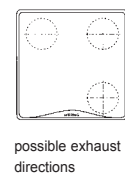

Exhaust air vent top: standard

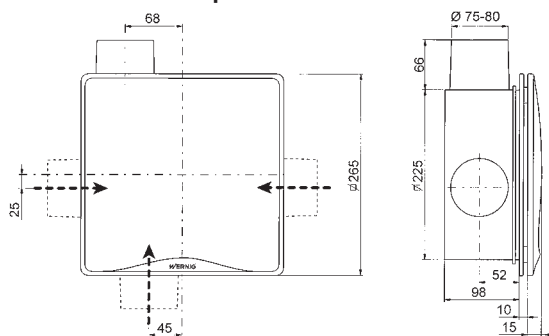

Exhaust air vent rear: special design

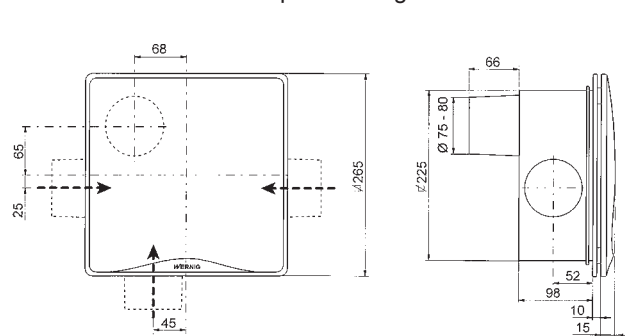

←--- Intake manifold options

←--- Intake manifold options

FLUSH-MOUNTED FanECO – Energy-Saving Motor – SILENT ECO U ... series

Pressure-volume flow characteristic curve of the **complete** fan SILENT ECO U

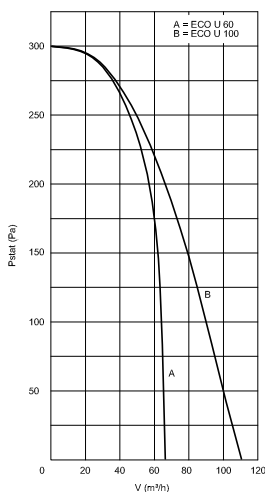

TECHNICAL DATA

SILENT ECO U Ø 80 top

Type	SILENT ECO U 60 (1-speed)	SILENT ECO U 60 GL (2-speed)	SILENT ECO U 100 (1-speed)	SILENT ECO U 100 GL (2-speed)
Exhaust volume flow calculation	67 m³/h	67/27 m³/h	111 m³/h	111/27 m³/h
Power input	11,2 W	11,2/4,8 W	27,3 W	27,3/4,8 W
Spec. fan power	0,17 Wh/m³	0,17/0,18 Wh/m³	0,25 Wh/m³	0,25/0,18 Wh/m³
Voltage	230 V~, 50 Hz	230 V~, 50 Hz	230 V~, 50 Hz	230 V~, 50 Hz
Sound pressure level*	36 dB(A)	36/24 dB(A)	46 dB(A)	46/24 dB(A)

SILENT ECO U Ø 80 rear

Type	SILENT ECO U 60 (1-speed)	SILENT ECO U 60 GL (2-speed)	SILENT ECO U 100 (1-speed)	SILENT ECO U 100 GL (2-speed)
Exhaust volume flow calculation	66 m³/h	66/27 m³/h	107 m³/h	107/27 m³/h
Power input	11,2 W	11,2/4,5 W	26,9 W	26,9/4,5 W
Spec. fan power	0,17 Wh/m³	0,17/0,17 Wh/m³	0,25 Wh/m³	0,25/0,17 Wh/m³
Voltage	230 V~, 50 Hz	230 V~, 50 Hz	230 V~, 50 Hz	230 V~, 50 Hz
Sound pressure level*	37 dB(A)	37/24 dB(A)	44 dB(A)	44/24 dB(A)

* related to a reverberation time of 0,5 s according to ÖNORM EN ISO 16032

TECHNICAL INFORMATION

Base load GL means that the motor has a 2-speed design. A multitude of switching variations make it possible to adapt the operating modes to suit the building's situation. The base load (or low level) is activated for instance via an on/off switch (not possible in conjunction with a delayed shut-off relay) or hygrostat or is permanently on. The high level can be activated as needed via an on/off switch, delayed shut-off relay, hygrostat, etc.

PACKAGING

Fans of the SILENT ECO U series are available in 2 convenient packaging units:

1. For preliminary installation:

Casing complete with integrated air backflow damper, conical exhaust air vent Ø 75 – 80 mm, snap-fit recyclable dirt cover, a connection manifold for WC bowl or adjoining room extraction is available against surcharge.

2. For completion:

Fans unit, pre-wired and pluggable (available if desired with a delayed shut-off relay or 2-speed in GL design against surcharge). High-gloss facing, silenced, 2-part with filter (also available on request with a HGEECO hygrostat against surcharge).

WIRING DIAGRAMS

one-speed design
On/Off via pre-installed switch

with internal delayed shut-off relay **NRS, NRS/E, INS/ECO** or base load design **GL** or integrated hygrostat **HGEECO**

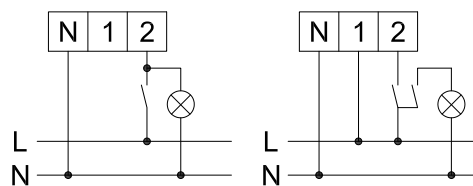

Other switching modes and special circuits on request
Attention: a 2-pole on/off switch must be used for all switching variants with the exception of the single-speed design (inverse voltage on terminal 2)

DIAGRAMS

for determining the rising mains diameter in accordance with Austrian Standard ÖNORM H 6036 [see page 3.11](#)

FLUSH-MOUNTED FanECO – Energy-Saving Motor – SILENT ECO U ... F90 series

Certified fire protection – fire resistance class FLI 90

Flush-mounted fan for bathrooms, WCs, non-commercial kitchens (exhaust air of the room), storage rooms, ... suitable for connection to a share rising mains (single pipe system), for wall and ceiling installation.

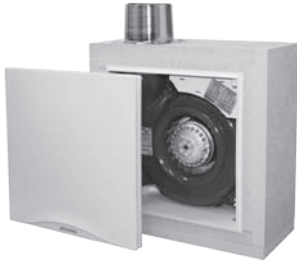

TECHNICAL DESCRIPTION

- certified fire protection – fire protection class FLI 90, certified by state-authorized test institute MA 39 analogue to Austrian Standard ÖNORM M 7625 pursuant to the OIB principle of utilisation
- pressure/volume flow characteristic curve certified pursuant to Austrian Standard ÖNORM H 6036, air backflow flap designed as a cold smoke damper, temperature resistant up to 200°C, air leak rate <math><0.01 \text{ m}^3/\text{h}</math>, certified by accredited inspecting authority TÜV SÜD Munich
- **(OVE)**-certified, hose-proof IPX5, suitable for installation in the safe area of showers and baths
- protection class II, no grounding conductor required

- easy to exchange air backflow flap
- silenced designer facing and filter bracket in high-gloss look, white, ~RAL 9016
- easy to exchange large-surface filter
- device pivots by 10° for perpendicular equalisation plaster equalisation up to -30 mm
- fan unit with Quick Snap technology for screwless quick fitting with a vibration-absorbing bracket for insulation against structure-borne noise
- easy to install silenced facing through the use of self-tapping screws
- trouble-free electrical connection through pre-wired pluggable motor including control electronics and connection for a pluggable delayed shut-off relay type NRS or NRS/E or an interval delayed shut-off device type INS/ECO
- max. permissible exhaust air temperature 40°C

MOTOR

Maintenance-free, energy-saving external rotor motor with constant volume flow characteristic with a direct-mounted, low-energy, low-noise, high-performance impeller and built-in thermal contact, pre-wired and pluggable, 2-speed GL design

FAN UNIT

Volute casing with base plate made of tough polycarbonate, temperature resistant up to 150°C

CASING

Fire resistant casing made of silicate fibre **40 mm fire resistant panels on all sides** with integrated cold smoke damper, metal exhaust air vent $\text{Ø} 80$ to the top (or to the rear) and **integrated, maintenance-free damper against fire transmission**, certified and suitable for installation in fire containment walls from 40 mm (e. g. 2x20 mm Rigips-Ridurit).

ACCESSORIES (against surcharge)
MBM installation bracket – required for fitting the UP casing beneath cladding or for ceiling installation.



INSTALLATION VARIANTS

Exhaust air vent top

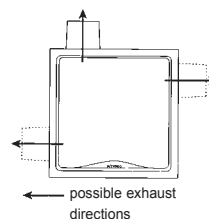

INSTALLATION VARIANTS

Exhaust air vent rear

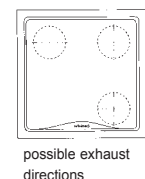

DIMENSIONS

Fan with an additional intake manifold $\text{Ø} 80$ mm with integrated, maintenance-free damper against fire transmission available on left, right or bottom - state position when placing order.

Type designation SILENT ECO U 60 ... F90 2 (see 3 options shown below as dashed lines).

Exhaust air vent top: standard

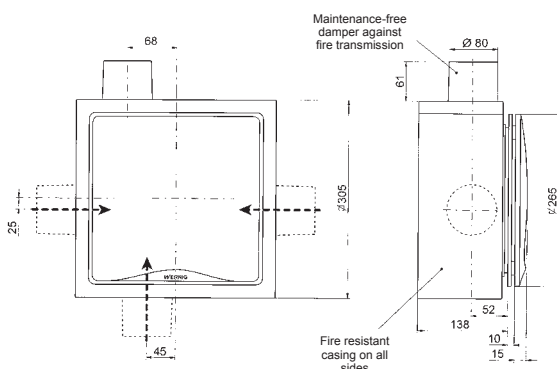

Exhaust air vent rear: special design

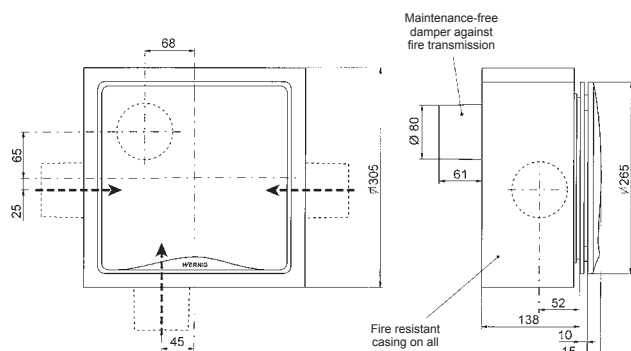

FLUSH-MOUNTED Fan ECO – Energy-Saving Motor – SILENT ECO U ... F90 series

Certified fire protection – fire resistance class FLI 90

Pressure-volume flow characteristic curve of the complete fan SILENT ECO U ... F90

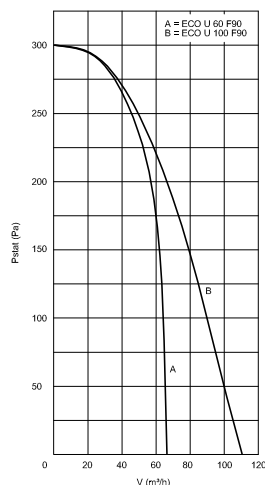

TECHNICAL DATA

SILENT ECO U ... F90 Ø 80 top

Type	SILENT ECO U 60 F90 (1-speed)	SILENT ECO U 60 GL F90 (2-speed)	SILENT ECO U 100 F90 (1-speed)	SILENT ECO U 100 GL F90 (2-speed)
Exhaust volume flow calculation	67 m³/h	67/27 m³/h	111 m³/h	111/27 m³/h
Power input	11,2 W	11,2/4,8 W	27,3 W	27,3/4,8 W
Spec. fan power	0,17 Wh/m³	0,17/0,18 Wh/m³	0,25 Wh/m³	0,25/0,18 Wh/m³
Voltage	230 V~, 50 Hz	230 V~, 50 Hz	230 V~, 50 Hz	230 V~, 50 Hz
Sound pressure level*	36 dB(A)	36/24 dB(A)	46 dB(A)	46/24 dB(A)

SILENT ECO U ... F90 Ø 80 rear

Type	SILENT ECO U 60 F90 (1-speed)	SILENT ECO U 60 GL F90 (2-speed)	SILENT ECO U 100 F90 (1-speed)	SILENT ECO U 100 GL F90 (2-speed)
Exhaust volume flow calculation	66 m³/h	66/27 m³/h	107 m³/h	107/27 m³/h
Power input	11,2 W	11,2/4,5 W	26,9 W	26,9/4,5 W
Spec. fan power	0,17 Wh/m³	0,17/0,17 Wh/m³	0,25 Wh/m³	0,25/0,17 Wh/m³
Voltage	230 V~, 50 Hz	230 V~, 50 Hz	230 V~, 50 Hz	230 V~, 50 Hz
Sound pressure level*	37 dB(A)	37/24 dB(A)	44 dB(A)	44/24 dB(A)

* realted to a reverberation time of 0,5 s according to ÖNORM EN ISO 16032

INSTALLATION

Installation must follow the installation and operating instructions provided to ensure compliance with fire protection criteria of FLI 90. The standard should be requested in advance for planning purposes. The details and information contained in the datasheets are based on our current knowledge and the standards and regulations applicable at the time of publication.

TECHNICAL INFORMATION

Base load GL means that the motor has a 2-speed design. A multitude of switching variations make it possible to adapt the operating modes to suit the building's situation. The base load (or low level) is activated for instance via an on/off switch (not possible in conjunction with a delayed shut-off relay) or hygrostat or is permanently on. The high level can be activated as needed via an on/off switch, delayed shut-off relay, hygrostat, etc.

PACKAGING

Fans of the SILENT ECO U ... F90 series are available in 2 convenient packaging units:

1. For preliminary installation:

Casing complete with integrated air backflow damper, conical exhaust air vent Ø 80 mm, recyclable clip-on dirt cover, a connection manifold for WC bowl or adjoining room extraction is available against surcharge.

2. For completion:

Fan unit, pre-wired and pluggable (available if desired with a delayed shut-off relay or 2-speed in GL design against surcharge). High-gloss facing, silenced, 2-part with filter (also available on request with a HGEECO hygrostat against surcharge).

WIRING DIAGRAMS

one-speed design
On/Off via pre-installed switch

with internal delayed shut-off relay NRS, NRS/E, INS/ECO or base load design GL or integrated hygrostat HGEECO

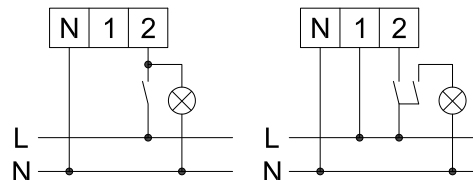

Other switching modes and special circuits on request
Attention: a 2-pole on/off switch must be used for all switching variants with the exception of the single-speed design (inverse voltage on terminal 2)

DIAGRAMS

for determining the rising mains diameter in accordance with Austrian Standard ÖNORM H 6036 see page 3.11

SURFACE-MOUNTED Fan **ECO** – Energy-Saving Motor – SILENT ECO A ... series

Surface-mounted fan for bathrooms, WCs, non-commercial kitchens (exhaust air of the room), storage rooms, ... suitable for connection to a share rising mains (single pipe system), for wall and ceiling installation.



TECHNICAL DESCRIPTION

- pressure/volume flow characteristic curve certified pursuant to Austrian Standard ÖNORM H 6036, air backflow flap designed as a cold smoke damper, temperature resistant up to 200°C, air leak rate <math><0.01 \text{ m}^3/\text{h}</math>, certified by accredited inspecting authority TÜV SÜD Munich
- **OVE**-certified, hose-proof IPX5, suitable for installation in the safe area of showers and baths
- protection class II, no grounding conductor required

- easy to exchange air backflow flap
- silenced designer facing, surface-mounted frame and filter support in high gloss look, colour white, ~RAL 9016
- easy to exchange large-surface filter
- device pivots by 10° for perpendicular equalisation
- fan unit with Quick Snap technology for screwless quick fitting with a vibration-absorbing bracket for insulation against structure-borne noise
- easy to install silenced facing through the use of self-tapping screws
- trouble-free electrical connection through pre-wired pluggable motor including control electronics and connection for a pluggable delayed shut-off relay type NRS or NRS/E or an interval delayed shut-off device type INS/ECO
- max. permissible exhaust air temperature 40°C

MOTOR

Maintenance-free, energy-saving external rotor motor with constant volume flow characteristic with a directly attached, low-energy, low-noise, high-performance impeller and built-in thermal contact, pre-wired and pluggable, 2-speed GL design

FAN UNIT

Volute casing with base plate made of tough polycarbonate, temperature resistant up to 150°C

CASING

rigid, two-part surface-mounted casing in a high-gloss look, white, ~RAL 9016, with integrated cold smoke damper, exhaust air vent for pipes and hoses with a minimum inner diameter of 80 mm, sound-insulating sealing strip around the box on the rear

Fans are also available with a maintenance-free fire damper against fire transmission as a fire-prevention measure - see technical documentation for SILENT ECO A ... F90.

DIMENSIONS

Standard design

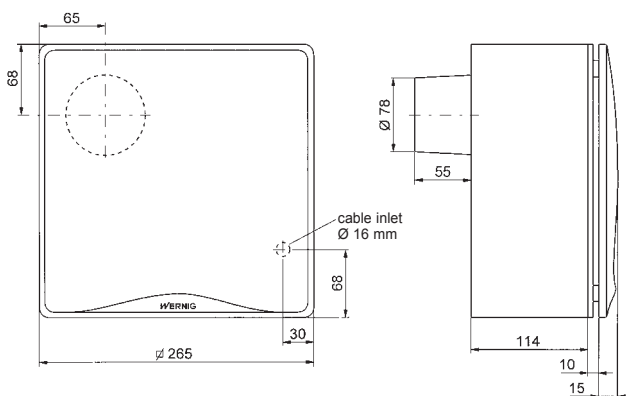

INSTALLATION VARIANTS

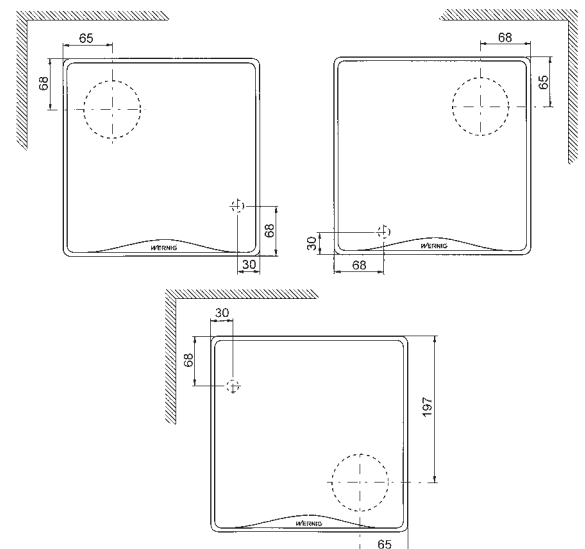

Surface-mounted casings are available on request with a top-mounted exhaust air vent.

SURFACE-MOUNTED FanECO – Energy-Saving Motor – SILENT ECO A ... series

Pressure-volume flow characteristic curve of the **complete** fan SILENT ECO A

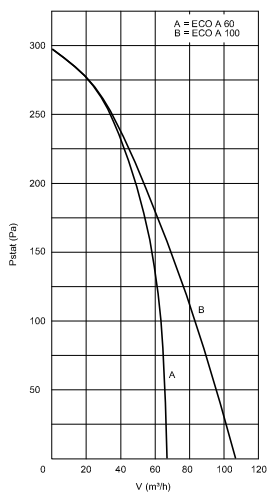

TECHNICAL DATA

SILENT ECO A 60

Type	SILENT ECO A 60 (1-speed)	SILENT ECO A 60 GL (2-speed)
Exhaust volume flow calculation	66 m³/h	66/27 m³/h
Power input	11,2 W	11,2/4,5 W
Spec. fan power	0,17 Wh/m³	0,17/0,17 Wh/m³
Voltage	230 V~, 50 Hz	230 V~, 50 Hz
Sound pressure level*	37 dB(A)	37/24 dB(A)

SILENT ECO A 100

Type	SILENT ECO A 100 (1-speed)	SILENT ECO A 100 GL (2-speed)
Exhaust volume flow calculation	107 m³/h	107/27 m³/h
Power input	26,9 W	26,9/4,5 W
Spec. fan power	0,25 Wh/m³	0,25/0,17 Wh/m³
Voltage	230 V~, 50 Hz	230 V~, 50 Hz
Sound pressure level*	44 dB(A)	44/24 dB(A)

* realted to a reverberation time of 0,5 s according to ÖNORM EN ISO 16032

TECHNICAL INFORMATION

Base load GL means that the motor has a 2-speed design. A multitude of switching variations make it possible to adapt the operating modes to suit the building's situation. The base load (or low level) is activated for instance via an on/off switch (not possible in conjunction with a delayed shut-off relay) or hygrostat or is permanently on. The high level can be activated as needed via an on/off switch, delayed shut-off relay, hygrostat, etc.

PACKAGING

Fans of the SILENT ECO A ... series are packaged in environmentally friendly boxes made from recycled paper fully ready for installation.

The scope of delivery includes wall plugs and screws for wall or ceiling installation.

WIRING DIAGRAMS

one-speed design
On/Off via pre-installed switch

with internal delayed shut-off relay **NRS, NRS/E, INS/ECO** or base load design **GL** or integrated hygrostat **HGEECO**

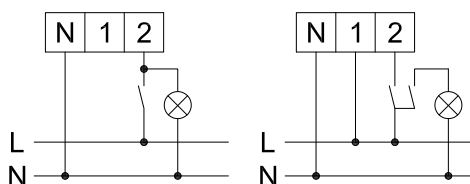

Other switching modes and special circuits on request
Attention: a 2-pole on/off switch must be used for all switching variants with the exception of the single-speed design (inverse voltage on terminal 2)

DIAGRAMS

for determining the rising mains diameter in accordance with Austrian Standard ÖNORM H 6036 [see page 3.12](#)

SURFACE-MOUNTED FanECO – Energy-Saving Motor – SILENT ECO A ... F90 series

Certified fire protection – fire resistance class FLI 90

Surface-mounted fan for bathrooms, WCs, non-commercial kitchens (exhaust air of the room), storage rooms, ... suitable for connection to a share rising mains (single pipe system), for wall and ceiling installation.



TECHNICAL DESCRIPTION

- certified fire protection – fire protection class FLI 90, certified by state-authorized test institute MA 39 analogue to Austrian Standard ÖNORM M 7625 pursuant to the OIB principle of utilisation
- pressure/volume flow characteristic curve certified pursuant to Austrian Standard ÖNORM H 6036, air backflow flap designed as a cold smoke damper, temperature resistant up to 200°C, air leak rate <math><0.01 \text{ m}^3/\text{h}</math>, certified by accredited inspecting authority TÜV SÜD Munich
- -certified, hose-proof IPX5, suitable for installation in the safe areas of showers and baths
- protection class II, no grounding conductor required

- easy to exchange air backflow flap
- silenced designer facing, surface-mounted frame and filter support in high gloss look, colour white, ~RAL 9016
- easy to exchange large-surface filter
- device pivots by 10° for perpendicular equalisation
- fan unit with Quick Snap technology for screwless quick fitting with a vibration-absorbing bracket for insulation against structure-borne noise
- easy to install silenced facing through the use of self-tapping screws
- trouble-free electrical connection through pre-wired pluggable motor including control electronics and connection for a pluggable delayed shut-off relay type NRS or NRS/E or an interval delayed shut-off device type INS/ECO
- max. permissible exhaust air temperature 40°C

MOTOR

Maintenance-free, energy-saving external rotor motor with constant volume flow characteristic with a directly attached, low-energy, low-noise, high-performance impeller and built-in thermal contact, pre-wired and pluggable, 2-speed GL design

FAN UNIT

Volute casing with base plate made of tough polycarbonate, temperature resistant up to 150°C

CASING

Rigid, two-part surface-mounted casing in a high-gloss look, white, ~RAL 9016, with integrated cold smoke damper, sound-insulating sealing strip around the box on the rear

FIRE PROTECTION Fire protection element NW 100/80 mm with integrated, maintenance-free damper against fire transmission

DIMENSIONS

Standard design

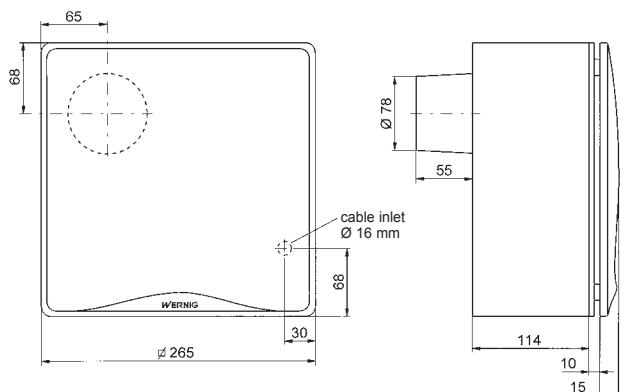

INSTALLATION VARIANTS

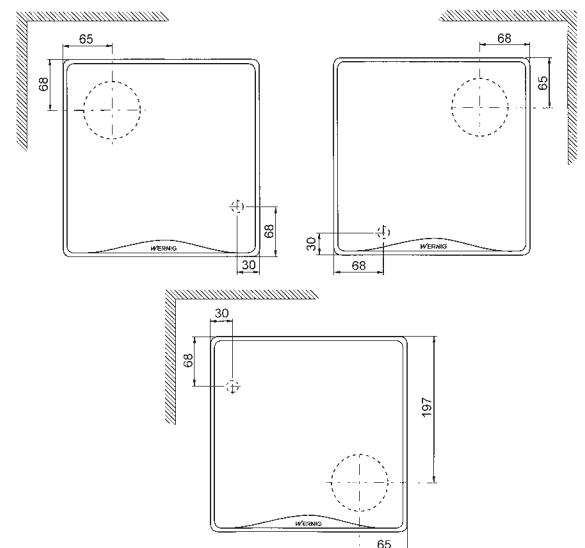

SURFACE-MOUNTED FanECO – Energy-Saving Motor – SILENT ECO A ... F90 series

Certified fire protection – fire resistance class FLI 90

Pressure-volume flow characteristic curve of the **complete** fan SILENT ECO A ... F90

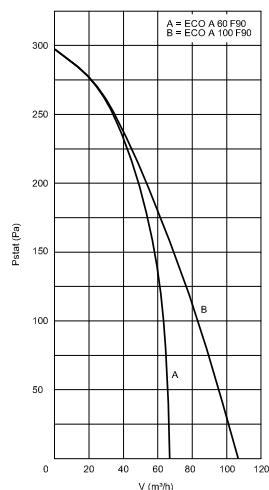

TECHNICAL DATA

SILENT ECO A 60 ... F90

Type	SILENT ECO A 60 F90 (1-speed)	SILENT ECO A 60 GL F90 (2-speed)
Exhaust volume flow calculation	66 m³/h	66/27 m³/h
Power input	11,2 W	11,2/4,5 W
Spec. fan power	0,17 Wh/m³	0,17/0,17 Wh/m³
Voltage	230 V~, 50 Hz	230 V~, 50 Hz
Sound pressure level*	37 dB(A)	37/24 dB(A)

SILENT ECO A 100 ... F90

Type	SILENT ECO A 100 F90 (1-speed)	SILENT ECO A 100 GL F90 (2-speed)
Exhaust volume flow calculation	107 m³/h	107/27 m³/h
Power input	26,9 W	26,9/4,5 W
Spec. fan power	0,25 Wh/m³	0,25/0,17 Wh/m³
Voltage	230 V~, 50 Hz	230 V~, 50 Hz
Sound pressure level*	44 dB(A)	44/24 dB(A)

* related to a reverberation time of 0,5 s according to ÖNORM EN ISO 16032

INSTALLATION

Installation must follow the installation and operating instructions provided to ensure compliance with fire protection criteria of FLI 90. The standard should be requested in advance for planning purposes. The details and information contained in the datasheets are based on our current knowledge and the standards and regulations applicable at the time of publication. Tested and suitable for fire containment walls from thicknesses of 40 mm upwards (e.g. 2x20 mm Rigips-Ridurit).

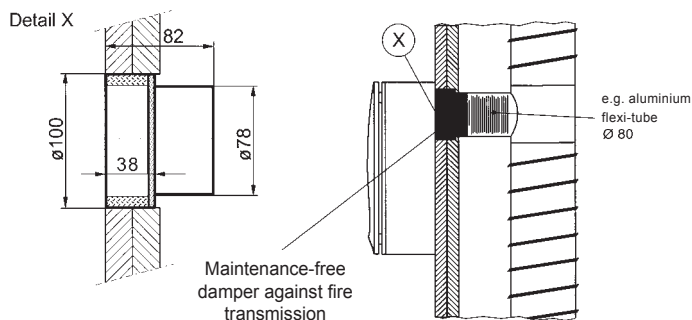

TECHNICAL INFORMATION

Base load GL means that the motor has a 2-speed design. A multitude of switching variations make it possible to adapt the operating modes to suit the building's situation. The base load (or low level) is activated for instance via an on/off switch (not possible in conjunction with a delayed shut-off relay) or hygrostat or is permanently on. The high level can be activated as needed via an on/off switch, delayed shut-off relay, hygrostat, etc.

PACKAGING

Fans of the SILENT ECO A ... F90 series are packaged in environmentally friendly boxes made from recycled paper fully ready for installation. The scope of delivery includes wall plugs and screws for wall or ceiling installation.

WIRING DIAGRAMS

one-speed design
On/Off via pre-installed switch

with internal delayed shut-off relay NRS, NRS/E, INS/ECO or base load design GL or integrated hygrostat HGEECO

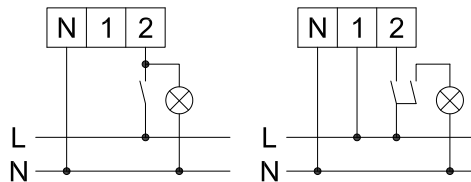

Other switching modes and special circuits on request
Attention: a 2-pole on/off switch must be used for all switching variants with the exception of the single-speed design (inverse voltage on terminal 2)

DIAGRAMS

for determining the rising mains diameter in accordance with Austrian Standard ÖNORM H 6036 see page 3.12

DIAGRAMS – ECO U series for determining the rising mains diameter in accordance with Austrian Standard ÖNORM H 6036

The diagrams show the maximum possible number of ventilation devices that can be connected to a rising mains of a specific diameter. Specifications are in accordance with Austrian Standard ÖNORM H 6036 based on an exhaust volume flow calculation and utilisation factor of 100%. For reasons of noise prevention it is recommended to reduce the number of possible devices per leg i.e. to restrict the air speed in the rising leg to approx. 6 m/sec. (see filling pattern diagrams).

The following diagrams apply to designs with the exhaust air vent at the top. The diagrams overleaf apply to designs with the exhaust air vent at the rear.

ECO U 60

1 device per full floor

Exhaust volume flow calculation 67 m³/h

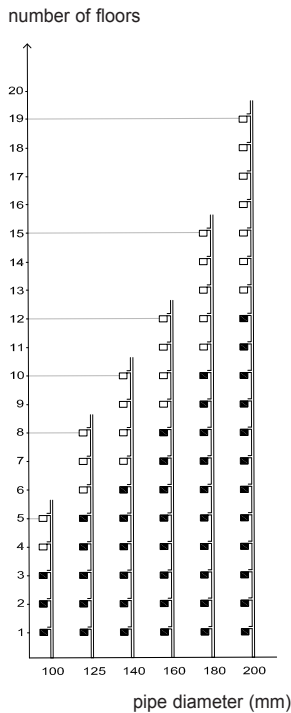

ECO U 60

2 devices per full floor

Exhaust volume flow calculation 67 m³/h per device

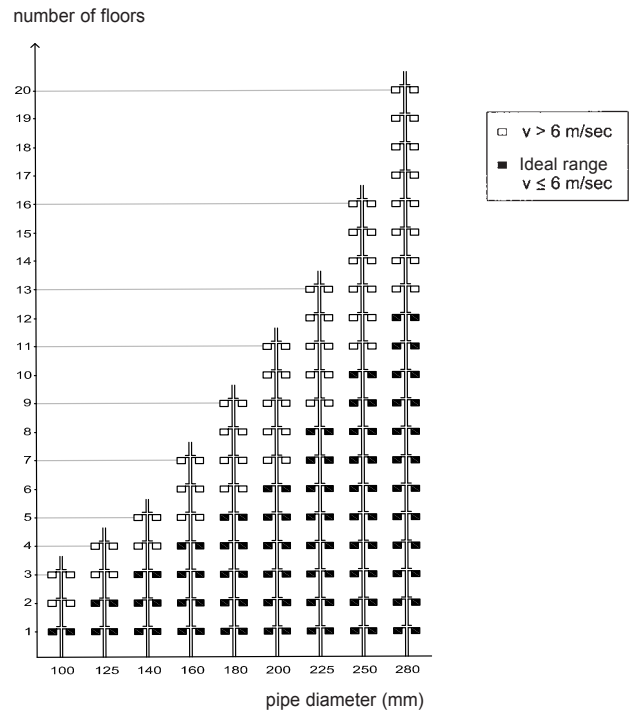

ECO U 100

1 device per full floor

Exhaust volume flow calculation 111 m³/h

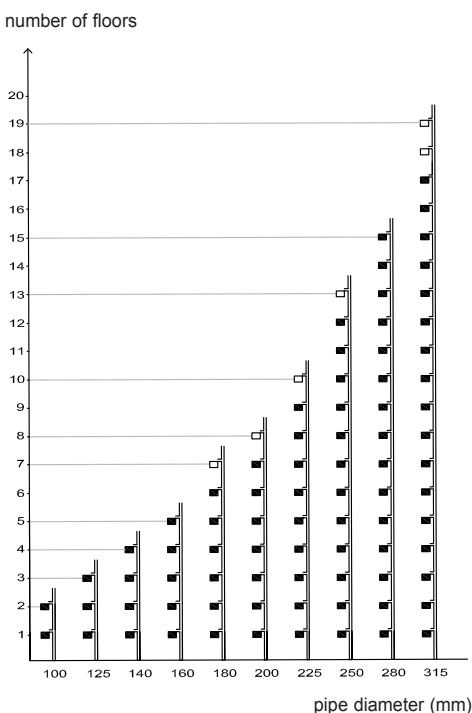

ECO U 100

2 devices per full floor

Exhaust volume flow calculation 111 m³/h per device

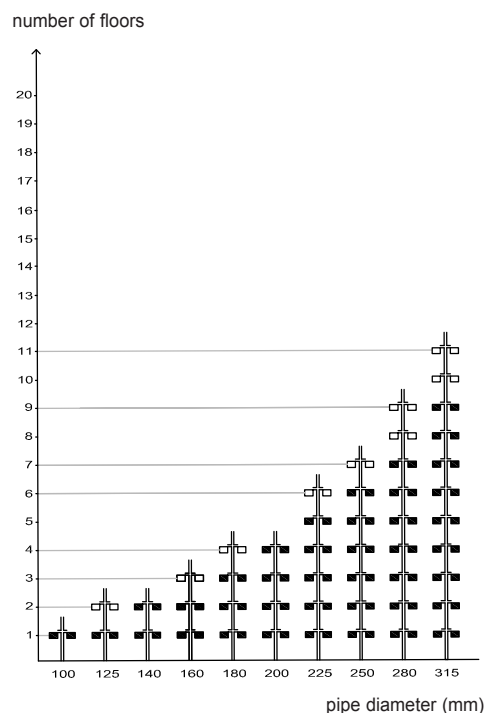

DIAGRAMS – ECO A series for determining the rising mains diameter in accordance with Austrian Standard ÖNORM H 6036

The diagrams show the maximum possible number of ventilation devices that can be connected to a rising mains of a specific diameter. Specifications are in accordance with Austrian Standard ÖNORM H 6036 based on an exhaust volume flow calculation and utilisation factor of 100%. For reasons of noise prevention it is recommended to reduce the number of possible devices per leg i.e. to restrict the air speed in the rising leg to approx. 6 m/sec. (see filling pattern diagrams).

ECO A 60

1 device per full floor

Exhaust volume flow calculation 66 m³/h

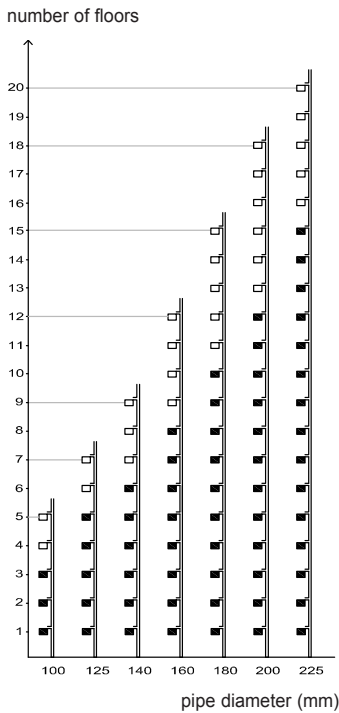

ECO A 60

2 devices per full floor

Exhaust volume flow calculation 66 m³/h per device

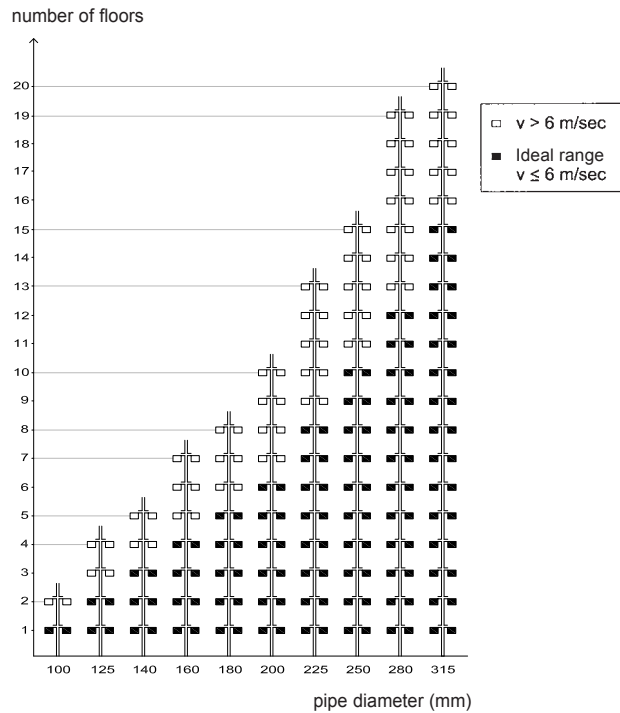

ECO A 100

1 device per full floor

Exhaust volume flow calculation 107 m³/h

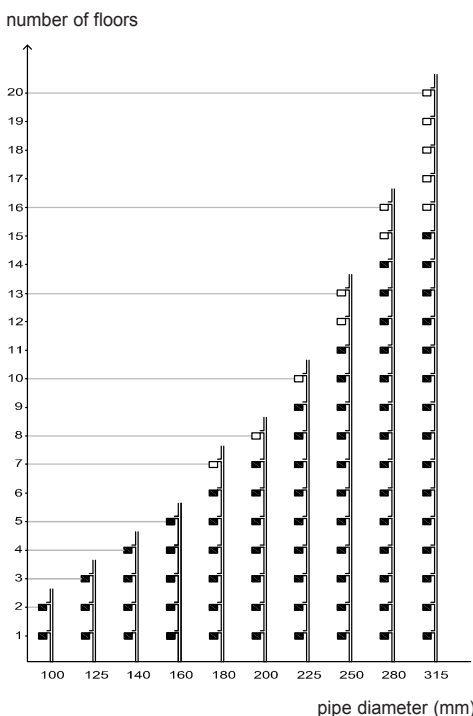

ECO A 100

2 devices per full floor

Exhaust volume flow calculation 107 m³/h per device

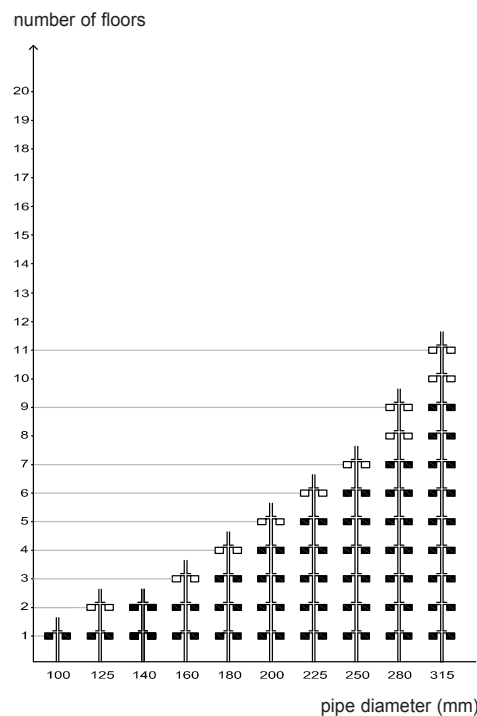

Delayed shut-off relay NR ..., interval lag time control unit INS/..., hygrostat .../HGE

Electronic delayed shut-off relay NRS, NRS/E

designed as a PCB with a protective coating. These electronic delayed shut-off relays are designed specifically for installation in the Silent ECO fan series and will only fit in these devices.

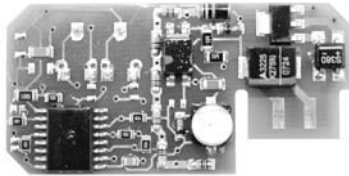

Type	NRS	NRS/E
	Fixed time settings, pluggable	Adjustable time settings, pluggable
Voltage	230 V~, 50 Hz	230 V~, 50 Hz
max. Load	0,8 A (160 W) inductive max.	0,8 A (160 W) inductive max.
max. ambient temp.	+60°C	+60°C
switch-on delay	1 min.	stepless from 0–3 min.
switch-off delay	7 min.	stepless from 1–20 min.

Electronic delayed shut-off relay NRG, NRG/E

in a plastic enclosure with 4 connection wires. These electronic delayed shut-off relays can be wired to the fan unit of bathrooms and WC fans where required, they are also suitable for (retrospective) installation in standard switch boxes.

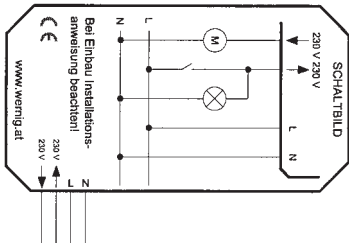

Type	NRG	NRG/E
	Fixed time settings	Adjustable time settings
Voltage	230 V~, 50 Hz	230 V~, 50 Hz
max. Load	0,8 A (160 W) inductive max.	0,8 A (160 W) inductive max.
max. ambient temp.	+60°C	+60°C
switch-on delay	1 min.	stepless from 0–3 min.
switch-off delay	7 min.	stepless from 1–20 min.
Dimensions	59 x 32 x 13 mm	59 x 32 x 13 mm

Interval lag time control unit INS/ECO, INS/E

The interval lag time control unit is used to control fans and ventilation systems and has two functions. It is operated via a commercially available on/off switch (provided by customer) that can also be used to switch the lights on and off.

INS/ECO

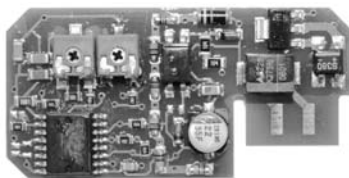

1. LAG TIME FUNCTION

When the fan and, where applicable, the lights are switched off the fan will continue to run for a steplessly adjustable lag time of between 1 and 20 minutes, after which it switches off automatically.

Type	INS/ECO
	Adjustable time settings, pluggable
Voltage	230 V~, 50 Hz
max. Load	0,8 A (160 W) inductive max.
max. ambient temp.	+60°C
switch-on delay	none
switch-off delay	stepless from 1–20 min.
Interval time	stepless from 1,5–12 hours

INS/E

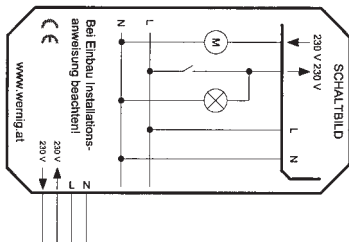

2. INTERVAL OPERATION

When the room is not in use, i.e. the fan/light is not switched on, the interval lag time control unit forces ventilation for a steplessly adjustable period of 1 to 20 minutes every 1,5 to 12 hours (steplessly adjustable lag time). Manual activation of the fan (or lights) interrupts and restarts the rhythm of the automatic ventilation program.

Type	INS/E
	Adjustable time settings
Voltage	230 V~, 50 Hz
max. Load	0,8 A (160 W) inductive max.
max. ambient temp.	+60°C
switch-on delay	none
switch-off delay	stepless from 1–20 min.
Interval time	stepless from 1,5–12 hours
Dimensions	59 x 32 x 13 mm

Hygrostat HGEECO

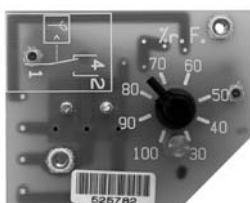

Built-in hose-proof hygrometer, protection class IPX5, for humidity-dependent fan control, integrated in Silent ECO silenced facing. Fastest reaction behaviour through the sensor's direct contact with ambient air. For a functionality description see page 3.2.

Type	HGEECO
Voltage	230 V~, 50 Hz
max. ambient temp.	0 to +60°C
Dimensions	59 x 47 x 33 mm